

United States FCC Compliance

This equipment has been tested and found to comply with the applicable limits of Part 15 of FCC Rules. These limits are designed to provide reasonable protection against harmful interference in a residential installation. This equipment generates, uses, and can radiate radio frequency energy and, if not installed and used in accordance with the instructions, may cause harmful interference to radio or TV reception, which can be determined by turning the equipment off and on. The user is encouraged to try to correct the interference by one or more of the following measures:

- Increase the separation between the equipment and receiver
- Connect the equipment into an outlet on a circuit different from that to which the receiver is connected
- Consult your cable company or an experienced radio/TV technician for help

Any changes or modifications not expressly approved by Scientific-Atlanta could void the user's authority to operate the equipment.

Important: The information shown in the FCC Declaration of Conformity paragraph below is a requirement of the FCC and is intended to supply you with information regarding the FCC approval of this device. *The phone numbers listed are for FCC-related questions only and not intended for questions regarding the connection or operation for this device. Please contact your cable service provider for any questions you may have regarding the operation or installation of this device.*

FCC Declaration of Conformity

This device complies with Part 15 of FCC Rules. Operation is subject to the following two conditions: 1) the device may not cause harmful interference, and 2) the device must accept any interference received, including interference that may cause undesired operation.

EXPLORER® Home Entertainment Server model:
Model E8000SD
Manufactured by: Scientific-Atlanta, Inc.;
4261 Communications Drive;
Atlanta, Georgia 30093-2860; USA
Telephone 770-236-1077

Software and Firmware Use

Scientific-Atlanta, Inc. owns copyrights to the software described in this document and furnishes the software to you under a license agreement. You may only use or copy this software in accordance with the terms of your license agreement.

Scientific-Atlanta, Inc. owns copyrights to the firmware in this equipment. You may only use the firmware in the equipment in which it is provided. Any reproduction or distribution of this firmware, or any portion of it, without the express written consent of Scientific-Atlanta, Inc. is prohibited.

Canada EMI Regulation

This Class B digital apparatus meets all requirements of the Canadian Interference Causing Equipment Regulations.

Cet appareil numérique de la classe B respecte toutes les exigences du Règlement sur le matériel brouilleur du Canada.

Trademarks

Explorer, Scientific-Atlanta, and the Scientific-Atlanta arcs logo are registered trademarks of Scientific-Atlanta, Inc. VCR Commander and "Bringing the Interactive Experience Home" are trademarks of Scientific-Atlanta, Inc.

Disclaimer

Scientific-Atlanta, Inc. assumes no responsibility for errors or omissions that may appear in this guide. Scientific-Atlanta reserves the right to change this guide at any time without notice.

United States: Scientific-Atlanta, Inc., 5030 Sugarloaf Parkway, Box 465447, Lawrenceville, GA 30042

Europe: Scientific-Atlanta Europe GmbH, Westerbachstrasse 28-32, 61476 Kronberg, Germany

Asia-Pacific: Scientific-Atlanta (Singapore) Pte. Ltd., 1 Claymore Drive, #08-11 Orchard Towers, Singapore 229594

Latin America: Scientific-Atlanta Argentina S.A., Carlos Pelligrini 1149, Piso 11º, Capital Federal 1011, Buenos Aires, Argentina

© 2002 Scientific-Atlanta, Inc.
Printed in USA
Part Number 745245 Rev B

All rights reserved.
www.scientificatlanta.com
July 2002

User's Installation Guide



Explorer® Home Entertainment Server



Bringing the **Interactive Experience Home™**

IMPORTANT RULES FOR SAFE OPERATION

Note to the Installer

Note to CATV System Installer (USA/Canada Only)

This reminder is provided to call the CATV system installer's attention to Article 820-40 of the NEC (Section 54, Part I of the Canadian Electrical Code), that provides guidelines for proper grounding and, in particular, specifies that the CATV cable ground shall be connected to the grounding system of the building, as close to the point of cable entry as practical.

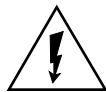

This symbol is intended to alert you that unsullied voltage within this product may have sufficient magnitude to cause electric shock. Therefore, it is dangerous to make any kind of contact with any inside part of this product.



CAUTION: To reduce the risk of electric shock, do not remove cover (or back). No user-serviceable parts inside. Refer servicing to qualified service personnel.

WARNING
TO PREVENT FIRE OR ELECTRIC SHOCK, DO NOT EXPOSE THIS UNIT TO RAIN OR MOISTURE.



This symbol is intended to alert you of the presence of important operating and maintenance (servicing) instructions in the literature accompanying this product.

Placement

Place this equipment in a location that is close enough to an electrical outlet and where the power cord is easily accessible to be disconnected from the wall outlet or from the rear panel of the Entertainment Server. Place this equipment on a stable surface. The surface must support the size and weight of this equipment.

WARNING:
Avoid personal injury and damage to this equipment. An unstable surface may cause this equipment to fall.

Ventilation

This equipment has openings for ventilation that protect it from overheating. To ensure the reliability of this equipment, follow these guidelines to avoid obstructing the openings:

- Do not place other equipment, lamps, books, or any other object on the top of this equipment.
- Do not place this equipment in any of the following locations:
 - On a bed, sofa, rug, or similar surface
 - Over a radiator or a heat register
 - In an enclosure, such as a bookcase or equipment rack, unless the installation provides proper ventilation

Cleaning the Equipment

Before cleaning this equipment, unplug it from the electrical outlet. Use a damp cloth to clean this equipment. Do not use a liquid cleaner or an aerosol cleaner. Do not use a magnetic/static cleaning device (dust remover) to clean this equipment.

Object and Liquid Entry

Never push objects of any kind into this product through openings as they may touch dangerous voltage points or short out parts that could result in a fire or electric shock. Do not expose this equipment to liquid or moisture. Do not place this equipment on a wet surface. Do not spill liquids on or near this equipment.

Accessories

Do not use accessories with this equipment unless recommended by your cable service provider.

Overloading

Do not overload electrical outlets, extension cords, or integral convenience receptacles, as this can result in a risk of fire or electric shock. For equipment that requires battery power or other sources to operate, refer to the operating instructions for that equipment.

Lightning and Power Surges

Ground (earth) your cable system to provide some protection against voltage surges and built-up static charges. Plug your equipment into a surge protector in order to reduce the risk of damage from lightning strikes and power surges. If you have questions, call your cable service provider.

Power Cord Protection

Arrange all power cords so that people cannot walk on the cords, place objects on the cords, or place objects against the cords, which can damage the cords. Give particular attention to the cords at the point at which the cord connects to the plug, at electrical outlets, and at the places where the cords exit the equipment.

Power Sources

A label on this equipment indicates the correct power source for this equipment. Operate this equipment only from an electrical outlet that has the voltage and frequency that the label indicates.

If you are unsure of the type of power supply to your residence, consult your cable service provider or your local power company.

Grounding

This equipment has a two-prong plug. Properly ground (earth) this equipment by inserting the plug into a grounded electrical, two-socket outlet.

If this plug is polarized, it has one wide prong and one narrow prong. This plug fits only one way.

CAUTION:
To prevent electric shock, match wide blade of plug to the wide slot, and then fully insert.

If you are unable to insert this plug fully into the outlet, contact an electrician to replace your obsolete outlet.

Servicing

Do not open the cover of this equipment. If you open the cover, your warranty will be void. Refer all servicing to qualified personnel only. Contact your cable service provider for instructions.

Damage that Requires Service

For damage that requires service, unplug this equipment from the electrical outlet. Refer service to qualified service personnel when any of the following occurs:

- There is damage to the power cord or plug
- Liquid enters the equipment
- A heavy object falls on the equipment
- There is exposure to rain or water
- Operation is not normal (the instructions in this guide describe the proper operation)
- If you drop this equipment, or damage the cabinet of this equipment
- If this equipment exhibits a distinct change in performance

Upon completion of any service or repairs to this equipment (home terminal), ask the service technician to perform safety checks to determine that the equipment is in proper operating condition.

Read and Retain These Instructions

- Read all of the instructions before you operate this equipment. Give particular attention to all safety precautions. Retain the instructions for future reference.
- Comply with all warning and caution statements in the instructions. Observe all warning and caution symbols that are affixed to this equipment.
- Comply with all instructions that accompany this equipment.

Welcome!

Congratulations on adding the Scientific-Atlanta® Explorer® Home Entertainment Server (Entertainment Server) to your television viewing experience!

The Entertainment Server is equipped with the following Personal Video Recorder (PVR) and picture-in-picture (PIP) capabilities:

- You can use the PVR feature to record a TV program while you view a different program, or record two programs simultaneously.
- You can use the PIP feature to view another program even if your TV does not have PIP capability.

Contact your cable service provider for more information and the availability of these features.

Use the instructions in this guide to install the Entertainment Server, to become familiar with the keys on the front panel of the Entertainment Server, and to access your cable services. Then, begin enjoying the features of the Explorer Home Entertainment Server.

Explorer eClub

To obtain additional information about the Explorer Home Entertainment Server, Scientific-Atlanta invites you to join the Explorer eClub. This online club provides news and "what's up" information about the Entertainment Server and offers you a chance to win prizes and other premium items.

To join the Explorer eClub, you must know the serial number of your Entertainment Server. The number is located on a bar code label on the back panel of your Entertainment Server and looks similar to this example:



Write the serial number here: _____

To access the Explorer eClub Web site type: www.scientificatlanta.com/explorerclub

Before Installing the Entertainment Server

Before you begin to install the Entertainment Server:

- Read the IMPORTANT RULES FOR SAFE OPERATION section of this guide.
- Locate the Entertainment Server serial number, which is on a bar code on the back panel of the Entertainment Server. You will need this serial number to join the Explorer eClub. Also, if your system requires troubleshooting in the future, your cable service provider may ask for the serial number.
- If you plug the Entertainment Server into an outlet that is controlled by a wall switch, keep the switch in the ON position. The on-screen guide is updated nightly. If the wall switch is in the OFF position, your Entertainment Server will not receive the latest programming updates.
- Keep the top of the Entertainment Server free of all objects and electronic devices, including your TV.
- It is recommended that you use a surge protector with your cable equipment and electronic devices.

Entertainment Server Front Panel

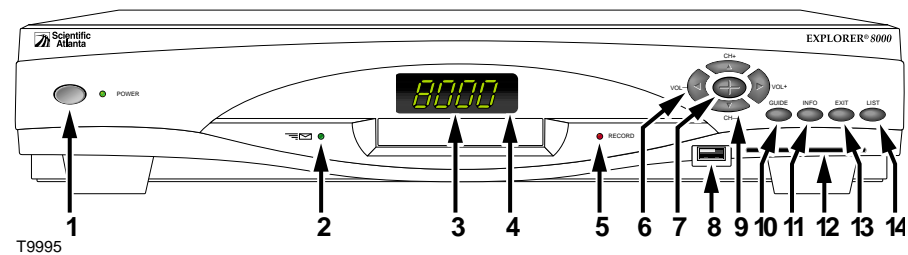

- | | |
|-----------------------------------|---|
| 1 Power | Provides power to the Entertainment Server. The light to the right of the Power key illuminates when the power is on. |
| 2 Message Indicator | Indicates a message from your cable service provider is waiting when blinking or illuminated. To access the message press the Info key. |
| 3 LED Display | Displays the selected channel number and time of day |
| 4 IR Sensor control | Receives the infrared signal from the remote |
| 5 Recording Indicator | Indicates the PVR feature is active when illuminated |
| 6 VOL+ and VOL- | Increases and decreases volume |
| 7 Select | Accesses your on-screen selection |
| 8 USB Port (Universal Serial Bus) | Connects to external equipment, such as a keyboard, external modem, or similar equipment* |
| 9 CH+ and CH- | Scrolls up and down through the channels |
| 10 Guide | Accesses on-screen services, such as the on-screen guide, video-on-demand, or pay-per-view |
| 11 Info | Displays a description of the selected program; available from the on-screen guide and while viewing a program |
| 12 Smart Card Slot | Allows smart card access* |
| 13 Exit | Exits menus, on-screen guide, and program information |
| 14 List | Accesses the list of recorded programs displayed on the TV screen |

* Contact your cable service provider for more information

Entertainment Server Back Panel

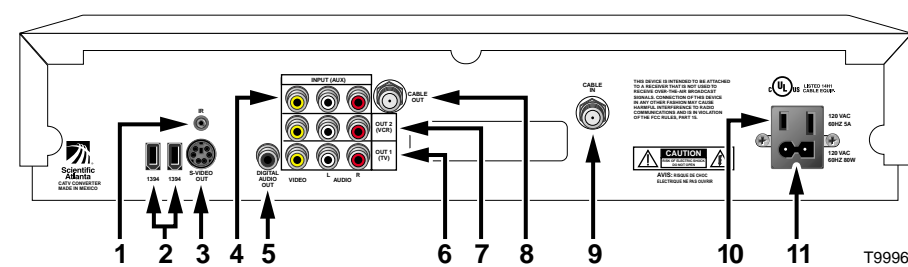

- | | |
|-----------------------|---|
| 1 IR Port | Connect to optional VCR Commander service |
| 2 1394 | Connect to optional 1394-equipped devices |
| 3 S-Video Out | Connect to S-Video input of TV or VCR (standard definition) |
| 4 Auxiliary Input | Connect to video and left/right (L/R) audio output of external device |
| 5 Digital Audio Out | Connect to external digital surround-sound receiver |
| 6 TV Out | Connect to video and left/right (L/R) audio inputs of a TV (standard definition). The video outlet is also referred to as COMPOSITE video |
| 7 VCR Out | Connect to video and left/right (L/R) audio inputs of a VCR |
| 8 Cable Out | Connect to cable input of TV or VCR (standard definition) |
| 9 Cable In | Connect to cable signal from cable service provider |
| 10 AC Switched Outlet | Connect the AC power cord from another device, such as a TV |
| 11 AC Power Input | Connect the Entertainment Server to an AC electrical outlet |

Installing the Entertainment Server

Connect the Entertainment Server a Stereo TV and Stereo VCR

Use the connection diagram and follow these steps to connect the Explorer Home Entertainment Server to your television.

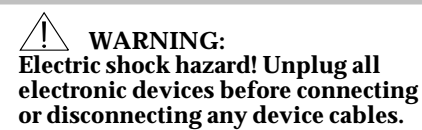

- Unplug all electronic devices before connecting the Entertainment Server.
- Connect the Entertainment Server to your TV and VCR as shown in the diagram.
- Connect the Entertainment Server to the coaxial cable coming from the wall.
- Plug the Entertainment Server and the TV into an AC power source.
- Turn on the power to your TV, and set the input channel assigned by your cable service provider (channel 3 or 4).

Important: Do not press the Power key on the Entertainment Server yet.

6. Wait for the time to display on the LED display.

Important: It takes 2 to 3 minutes for the Entertainment Server to be updated with the latest programming and service information. When the front panel displays the time, the update is complete.

7. Press the Power key on the Entertainment Server.

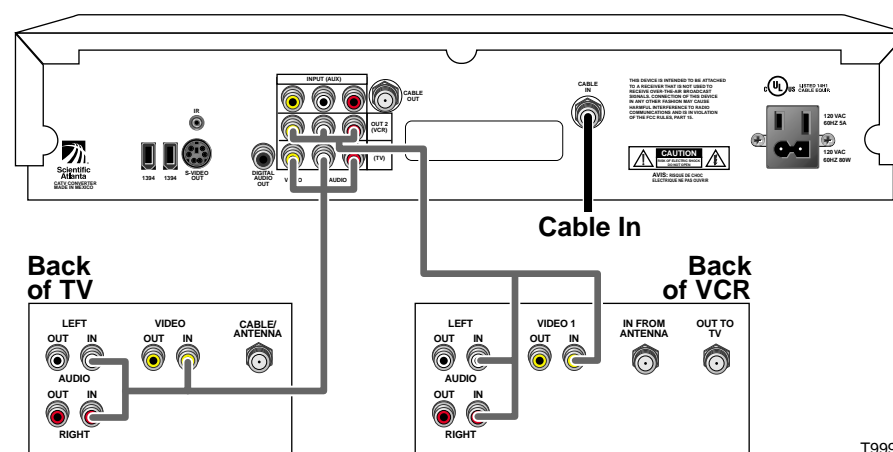

Cables Needed for Typical TV/VCR Setup

- 2 Sets of Video/Stereo Audio Cables

Audio Output

- The audio output from the CABLE OUT is monaural (non-stereo).
- The audio output from the AUDIO OUT LEFT and RIGHT is stereo.
- If you connect to S-VIDEO OUT (item 3 on the back panel diagram), you must also connect the LEFT and RIGHT AUDIO OUT on the Entertainment Server to the LEFT and RIGHT AUDIO IN connectors on your TV, VCR, or stereo to experience stereo sound.
- If you connect to TV OUT (item 6 on the back panel diagram), you must also connect the LEFT and RIGHT AUDIO OUT on the Entertainment Server to the LEFT and RIGHT AUDIO IN connectors on your TV, VCR, or stereo to experience stereo sound.

Other Types of Connections

If you are connecting the Explorer Home Entertainment Server to a different type of TV, VCR, or to additional devices, access our Web site for connection information: www.scientificatlanta.com/explorerclub

Accessing Programs

Access Cable Services and Programs

You can access your cable services and programs using the remote control or the keys on the front panel of the Entertainment Server. (Refer to your remote control user's guide for remote control programming instructions.)

- Press the Guide key to access the on-screen guide. The on-screen guide displays schedules of TV programs and other services available from your cable service provider, such as video-on-demand and pay-per-view programs.
- Use the arrow keys to highlight a program in the schedule.
- Press the Info key for a description of a specific program (either from the on-screen guide or while viewing a program).
- Press the Select key to view a specific program you have selected from the guide.

Access PVR and PIP Features

Accessing the PVR and PIP features requires using either the AllTouch® 8400 or 8410 Remote Control. Refer to the remote control and quick references guides provided by your cable service provider for instructions on accessing the PVR and PIP features.

Check and Correct

If your Entertainment Server does not perform as expected, check the following conditions:

- Verify that the power to your TV is turned on.
- If plugged into a wall switch, verify the switch is in the ON position.
- Verify that all cables are properly connected.
- Verify that your TV is tuned to the proper output channel (3 or 4).

If your Entertainment Server still does not perform as expected, check the following conditions:

No picture

- If your system includes a VCR and/or stereo, verify that you have properly connected them to the Entertainment Server.

No color

- Verify that the current TV program is broadcast in color.
- Adjust the TV color controls.

No sound

- If your setup includes a VCR and/or stereo, verify that you have properly connected them to the Entertainment Server.
- Verify that the volume is turned up.

The LED on the front panel displays question marks instead of the channel number.

Press the INFO key on the remote control or the front panel of the Entertainment Server. You may have pressed the Power key before all of the latest programming updates were received by the Entertainment Server.

The TV screen displays a message indicating that the Entertainment Server is automatically updating its software.

Wait for the time to display on the LED before continuing with your installation process. When the front panel displays the time, the update is complete.

Note: If you need further assistance, call your cable service provider.